

60

AGA series

60X60X25mm

●General Specification / 一般規格

- Motor / DC brushless motor
- Material / Frame : plastic(94V-0)
Impeller : plastic(94V-0)
- Bearing / Ball bearing;FMB
- Weight / 94g
- 馬達 / 直流單向無刷馬達
- 材質 / 框：鋁合金壓鑄
葉：塑膠(94V-0)
- 軸承 / 滾珠軸承;FMB
- 重量 / 94克



●Specification / 詳細規格 * 軸承/bearing B: 雙滾珠/ball bearing F:FMB S: 含油軸承/sleeve bearing

Model	Bearing	Voltage	Operating Vol.	Current	Speed	Max. Air Flow		Max. Static Pressure		Sound	Weight
機型	軸承	電壓	操作電壓	電流	轉速	最大風量		最大風壓		噪音	重量
P/N	B/S/F	V	V	A	RPM	m ³ /min	CFM	mm-H ₂ O	In-H ₂ O	dBA	g
AGA06025*12M	B	12	6.0~13.2	0.07	4000	0.55	19.44	4.29	0.17	29.68	94
AGA06025*12H	B	12	6.0~13.2	0.10	6000	0.83	29.47	9.21	0.36	38.09	94
AGA06025*12U	B	12	6.0~13.2	0.35	8000	1.12	39.55	16.06	0.63	44.68	94
AGA06025*12V	B	12	6.0~13.2	0.82	11000	1.55	54.8	30.39	1.20	53.97	94
AGA06025*24M	B	24	12.0~26.4	0.05	4000	0.55	19.44	4.29	0.17	29.68	94
AGA06025*24H	B	24	12.0~26.4	0.09	6000	0.83	29.47	9.21	0.36	38.09	94
AGA06025*24U	B	24	12.0~26.4	0.20	8000	1.12	39.55	16.06	0.63	44.68	94
AGA06025*24V	B	24	12.0~26.4	0.40	11000	1.55	54.8	30.39	1.20	53.97	94
AGA06025*48U	B	48	24.0~52.8	0.12	8000	1.12	39.55	16.06	0.63	44.68	94
AGA06025*48V	B	48	24.0~52.8	0.23	11000	1.55	54.8	30.39	1.20	53.97	94

● Drawing & panel out-cuts/ 圖面及出入風口

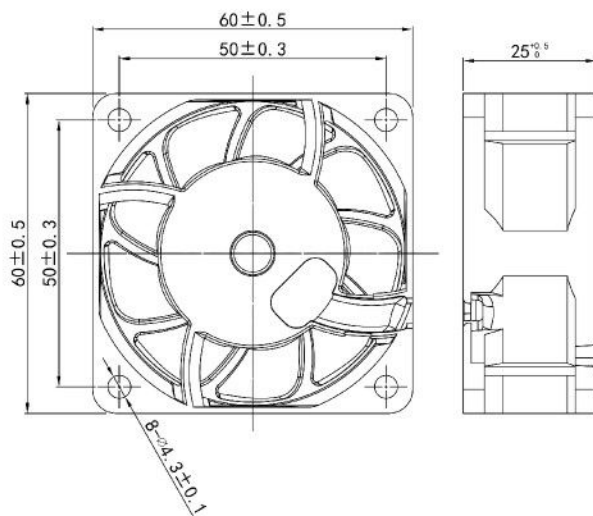

● Characteristic Curves/ 特性曲線

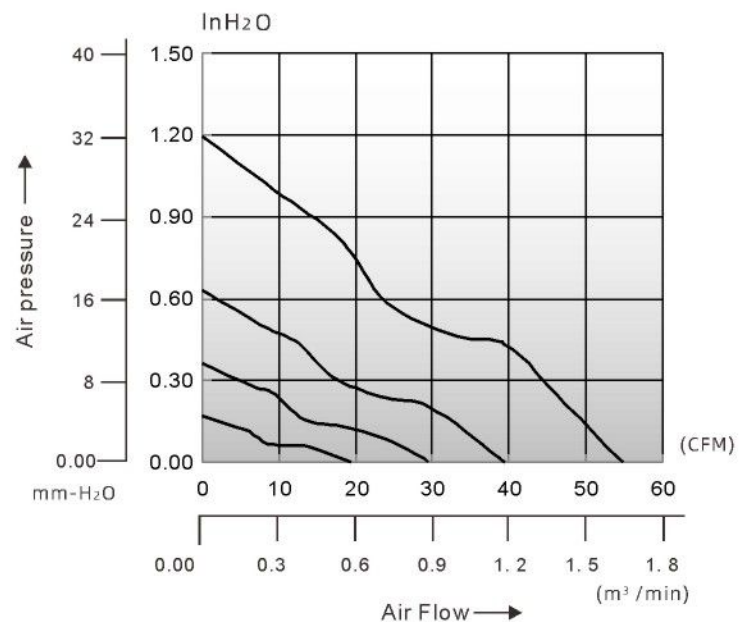

Specification is subject to change for improvement without notice / 基於改良的規格變更，不另行通知